



## Implementing MPC to Reduce Variability by Optimizing Control Valve Response

In industrial applications, two valves are often used to extend the range of loads that loops can handle. In this paper, a model predictive controller is configured to simultaneously manipulate a small valve and a large valve, eliminating the problems inherent in split-ranged and valve-position controllers. This provides the precision of control offered by the small valve with the range of control possible from the combination of the small and large valve



©Fisher-Rosemount Systems, Inc. 1996—2005 All rights reserved.

DeltaV, the DeltaV design, SureService, the SureService design, SureNet, the SureNet design, and PlantWeb are marks of one of the Emerson Process Management group of companies. All other marks are property of their respective owners. The contents of this publication are presented for informational purposes only, and while every effort has been made to ensure their accuracy, they are not to be construed as warranties or guarantees, express or implied, regarding the products or services described herein or their use or applicability. All sales are governed by our terms and conditions, which are available on request. We reserve the right to modify or improve the design or specification of such products at any time without notice.





## Contents

Introduction.....	4
Application Examples .....	4
Implementation Example .....	7
Controller Configuration.....	8
Controller Tuning .....	9
Discussion and Related Issues.....	11



## Figures

Figure 1 Split-range control for a neutralizer.....	5
Figure 2 Valve position controller for a neutralizer.....	6
Figure 3 Model predictive controller for rapid simultaneous throttling of two valves.....	7
Figure 4 Controlled and manipulated screens in DeltaV Predict .....	8
Figure 5 Penalty on moves and errors on controller generation screen in DeltaV Predict .....	9
Figure 6 Trend in MPC Operate of response of DeltaV Predict to disturbances and setpoints.....	10



## Introduction

In industrial applications, two valves are often used to extend the range of loads that loops can handle. Typically, the valves are split ranged where the small valve is throttled for low loads (low controller outputs) and the large valve is throttled for high loads (high controller outputs). A splitter block is used on the controller output to split a single controller output into set points for two set points for analog outputs. Ideally, the split range point or point of transition from the small to large valve is based on valve capacity to help linearize the loop. For example if the large valve has nine times the capacity of the small valve, the split range point should be 10% so that the small and large valves stroke from closed to wide open for a controller output of 0-10% and 10-100%, respectively.

Unfortunately, the large valve may have a larger deadband (backlash) and resolution limit (stick-slip) than the small valve because a rotary valve instead of a sliding stem valve was selected for the larger body size. Even if the large valve has the same deadband or resolution limit as the small valve, the variability introduced into the process is greater for the large valve because of its larger flow coefficient. Stick-slip causes a limit cycle in all processes and backlash causes a limit cycle in integrating or non-self-regulating processes and cascade loops.

Most loops limit cycle across the split range point because the friction is greatest when the large valve is near the closed position from the seating of the plug in sliding stem valves and the sealing of the ball or disc in rotary valves.

To address these issues, valve position controllers have been used to eliminate the split ranging. The original process PID controller output now goes to just the small valve. An integral only (I-only) valve position controller is added with the trim valve signal as its input, a mid throttle position, such as 50%, as its set point, and an output that only goes to the large valve. The valve position controller integral time is set larger than 5 times the product of the PID controller gain and integral time settings to make the interaction between the controllers negligible.

Consequently, the I-only valve position controller is too slow to handle disturbances and causes a slow limit cycle from the slip-stick in the large valve.

In this application note, a model predictive controller is configured to simultaneously manipulate the small and large valve eliminating the problems inherent in split ranged and valve position controllers. This provides the precision of control offered by the small valve with the range of control possible from the combination of the small and large valve.

## Application Examples

Small and large valves are used whenever there is a need to extend the rangeability of a final element. Common applications are steam header let down pressure control, jacket temperature control, and neutralizer pH control. In Figure 2, the pH controller AC1-1 output goes to a splitter block AY1-1 where it is split into separate signals for the small valve and large valve. In this application, the flow is throttled in parallel branches of the same reagent stream. For pH systems, the rangeability required for reagent flow can approach 10,000:1, which is theoretically reachable by the use of two Fisher control valves with digital positioners, where the small valve has about 1/10 the capacity of the large valve. However, the discontinuity and friction at the split range point makes this difficult to achieve in practice. Also, once the control is on the large valve, the precision of the small valve is not available.

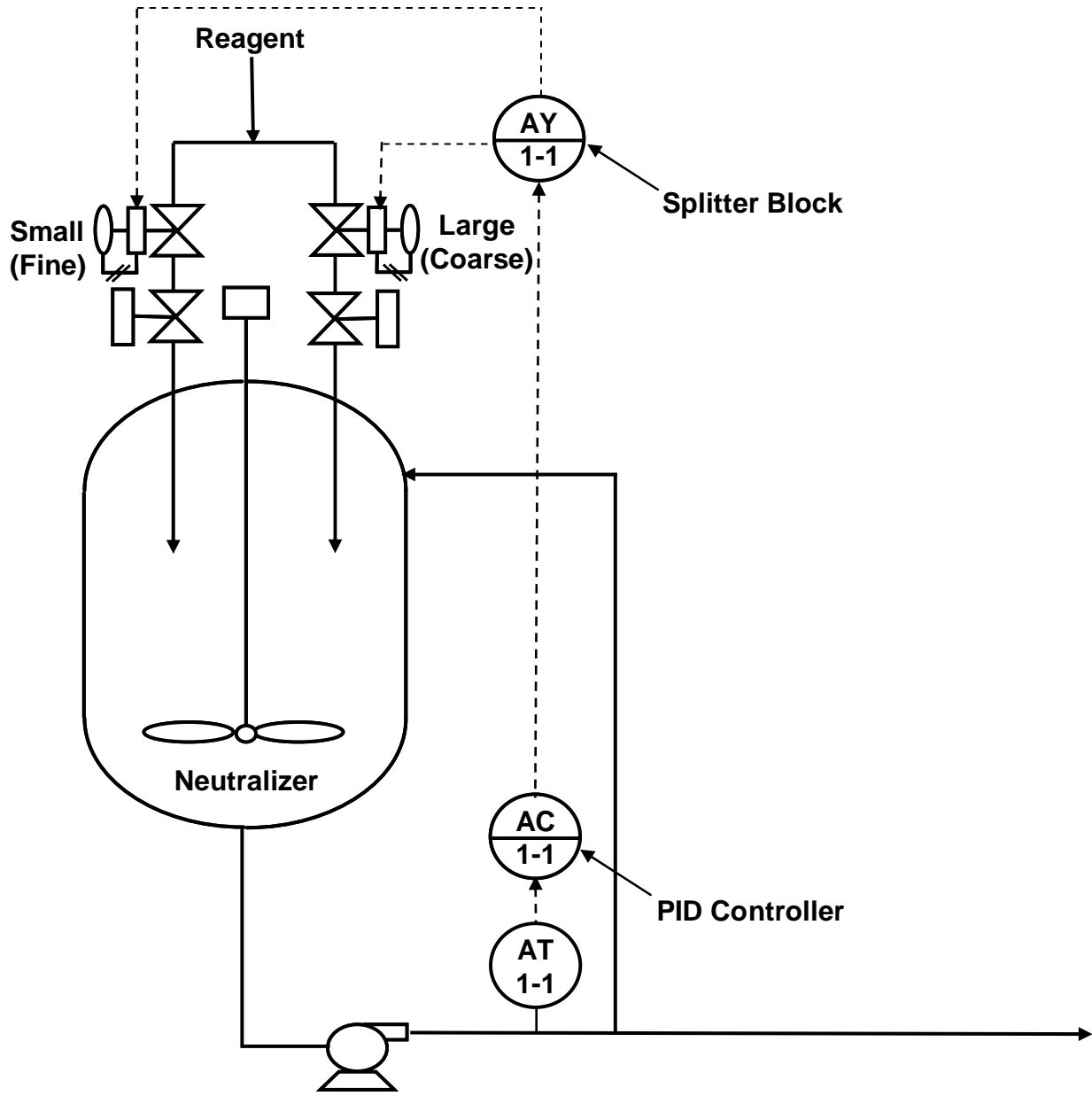

Figure 1 Split-range control for a neutralizer

Just putting the controller in automatic even though there is no disturbance can cause a sustained oscillation (limit cycle) from valve stick-slip or valve deadband in pressure, temperature, and composition control loops. The amplitude of the limit cycle is roughly the stick-slip or half deadband multiplied by the process gain. For a pH set point on the steep portion of a titration curve, the valve resolution and deadband requirement is extraordinary and approaches the resolution of the analog card output. To get the incredible rangeability and resolution demanded in pH systems, vessels in series are used with the largest valve on the first and the smallest valve on the last vessel. To avoid the considerable cost of multiple stages of neutralization, a valve position controller is employed as shown in Figure 2.

Since the valve pressure drop is relatively constant because of the low piping and fitting friction loss associated with the low reagent flow, there is relatively little interaction in terms of pressure. There is, of course, the interaction in terms of the effect of both flows on pH. The valve position controller (ZC1-1) below has a slow integral-only control action to keep the two loops from fighting. The controlled variable (CV) of ZC1-1 is the output of the pH controller (AC1-1), which is the implied valve position of the small valve. It is not necessary to use a read back of actual valve position since ZC1-1 is only trying to return the small valve in a mid throttle range by a slow adjustment of the large valve. Unfortunately, upsets that send the small valve to its output limit take a long time to be corrected by the slow ZC1-1.

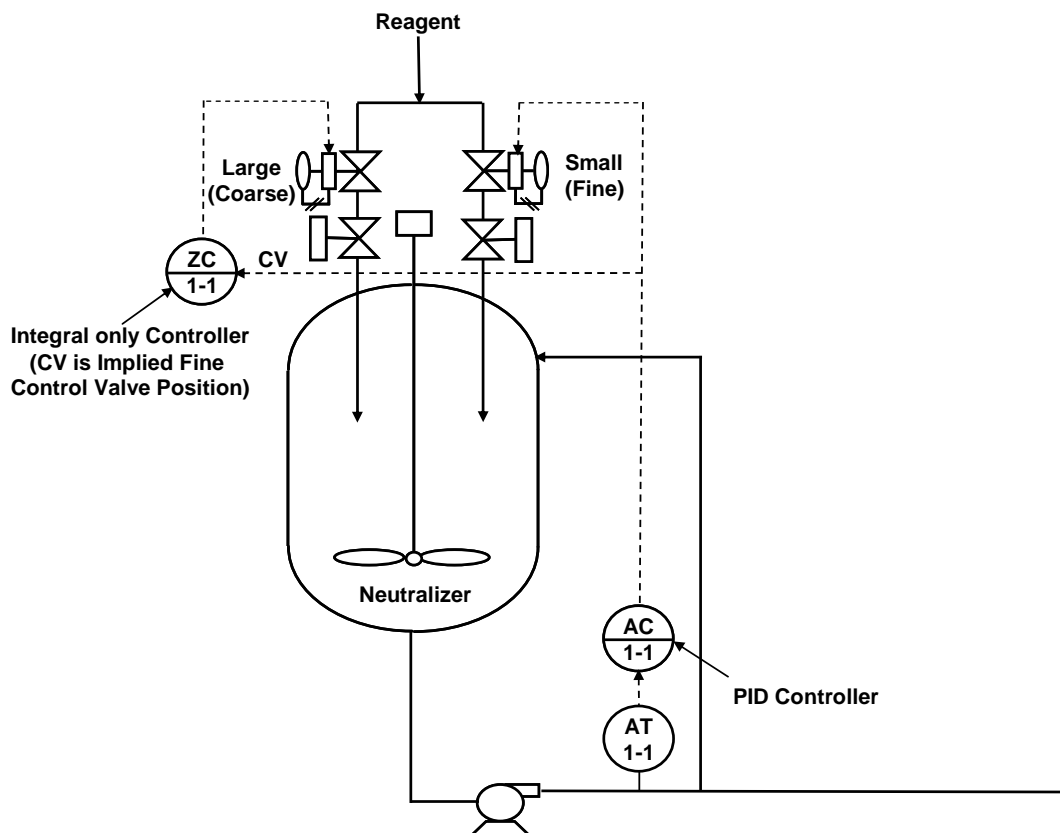

Figure 2 Valve position controller for a neutralizer

## Implementation Example

A model predictive controller (MPC) can rapidly and simultaneously throttle both valves to reject disturbances or reach new set points and keep the small valve in a mid throttle range. The MPC in Figure 3 has two manipulated variables (small and large valves), one optimization variable (small valve position), and one controlled variable (pH).



<i>MPC</i>		<i>manipulated variables</i>	
		<i>Small (Fine) Reagent Valve SP</i>	<i>Large (Coarse) Reagent Valve SP</i>
<i>controlled variable</i>	<i>Small (Fine) Reagent Valve SP</i>	—	<i>null</i>
<i>controlled variable</i>	<i>Neutralizer pH PV</i>		

Figure 3 Model predictive controller for rapid simultaneous throttling of two valves

The fine valve is usually faster than the coarse valve because it has a smaller actuator, which can translate to a faster pH response when the transportation and mixing delays from piping design and valve location are similar for both valves. Since the lower process gain associated with the smaller size of the trim valve introduces less variability into the process, the trim valve can be labeled the “fast low cost MV” and the coarse valve can be labeled the “slow high cost MV”. The labeling of “fast” or “slow” is more appropriate for header systems where the dead time from pressurization/depressurization of the actuator and getting through the deadband of the larger valve are significantly greater than transportation or mixing delays. The labeling of “low cost” and “high cost” is true not only because of the process variability but also the raw material or energy consumption associated with the respective valves.

The MPC could have been set up for optimization of the large valve to a minimum valve position. However the set point (target) for this minimization would need to be calculated based on the installed characteristics and capacities to keep the small valve from riding its output limit. This complication is unnecessary with the MPC shown in Figure 3, which works to insure the fine valve is always available.



## Controller Configuration

In DeltaV Predict, the number of controlled variables as extensible parameters for the model predictive control block MPC1 is specified as 2 (NOF\_CNTRL=2). This gives two controlled variables (CNTRL1 and CNTRL2) and two manipulated variables (MNPLT1 and MNPLT2).

MNPLT1 is the small valve (Fast Trim MV) and MNPLT2 is the large valve (Slow Coarse MV) as shown in Manipulated screen in Figure 4. The manipulated variables MNPLT1 and MNPLT2 are wired to the RCAS\_IN or CAS\_IN set points of the analog output (AO) blocks for the valves.

CNTRL1 is the set point for the Fast Trim Valve and “Observe” is chosen in the optimization column as shown in Controlled screen in Figure 4. Since an optimization strategy has been chosen, Predict knows inherently that you want to optimize MNPLT1 for CNTRL1 and will set up a pure unity gain model automatically between these two variables. Note that the user does not need to wire back MNPLT1 to CNTRL1 or identify this model. CNTRL2 is chosen to be the process variable of importance (Critical PV) with a default of “<none>” in the optimization column. The AI block AI1-1 OUT is wired to CNTRL1.

The screenshot shows the 'MPC1 Properties' window with the 'Controlled' tab selected. The table below represents the data shown in the window.

Name	Description	Track SP	SP Filter Time (secs)	SP Low Limit	SP High Limit	Optimization
CNTRL1	Fast Trim Valve	No	0	0	100	Observe Limit
CNTRL2	Critical PV	No	0	0	100	<none>

The screenshot shows the 'MPC1 Properties' window with the 'Manipulated' tab selected. The table below represents the data shown in the window.

Name	Description	Maximum MV Rate (EU per second)	Low Limit	High Limit
MNPLT1	Fast Trim Valve	10	0	100
MNPLT2	Slow Coarse Valve	10	0	100

Figure 4 Controlled and manipulated screens in DeltaV Predict



## Controller Tuning

In DeltaV Predict, the Penalty on Error (PE) is significantly decreased on the “Controller Generation” screen as shown in Figure 5. In this case, the PE was lowered from 1.0 to 0.1 to make the optimization of the small (trim) valve position much less important than the control of the Critical PV at its target. A longer than normal control horizon was chosen to make the results of Predict closer to that of PredictPro. The Penalty on Move (PM) was set for each MV to the value found by the automatic tuning algorithm in Predict-Pro based on the identified process gain and dead time. If the PM for the large valve was increased beyond the setting suggested by model dynamics, it could cause saturation of the small and a slow response of the Critical PV for large upsets or big set point changes.

The screenshot shows the "Controller Generation" window with the following settings:

- Control Horizon:** Radio buttons for 5 and 9. The 9 option is selected.
- Patience Factor (in seconds):** Four input fields for CNTRL1, CNTRL2, CNTRL3, and CNTRL4, all containing the value 0.
- Penalty On Error:** Radio buttons for Constant and Incremental. The Constant option is selected. Below are four input fields for values: 0.1, 1, 1, and 1.
- Penalty On Move:** Radio buttons for Constant and Decremental. The Constant option is selected. Below are four input fields for values: 5, 20, 3, and 3.

Buttons at the bottom: Defaults, Start, Close.

Figure 5 Penalty on moves and errors on controller generation screen in DeltaV Predict



The trend chart in MPC Operate in Figure 5 shows the response for large steps in load and set points for both the critical PV and the desired optimum position for the fine (trim) valve. Notice that for the successive load upsets, the large valve moves rather quickly to a new position that enables the small valve to return to its optimum. The load rejection is smooth and fast. Similarly, for a change in the set point of the critical PV from 50% to 70%, the large (coarse) valve moves to take care of the long term need at the new set point. Finally, a set point change in the small (trim) valve position from 50 to 60% shows only a small bump to the process. Normally, the operator would not be changing the optimum trim valve position, but a set point filter could be added for the optimization variable to prevent even a small bump.

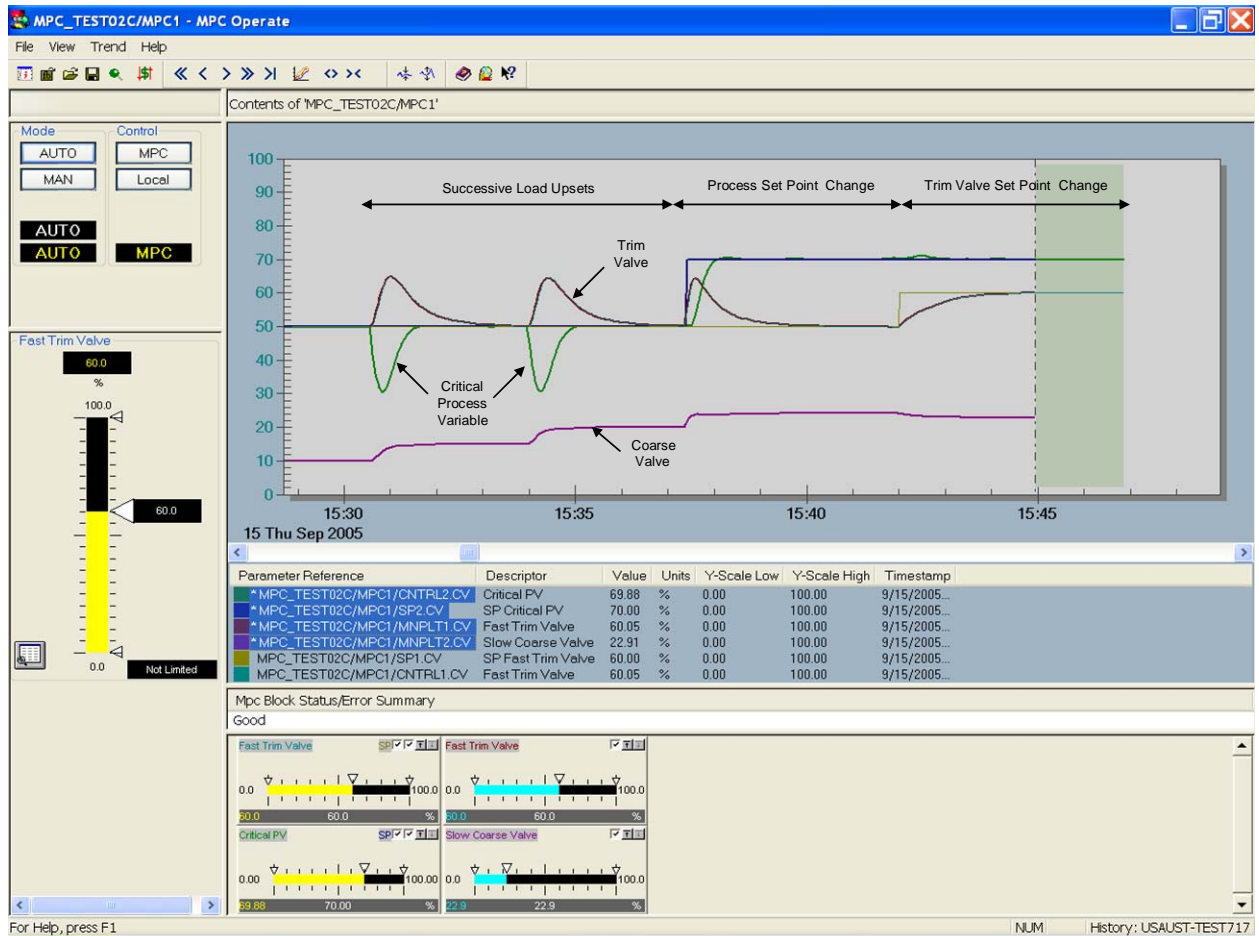

Figure 6 Trend in MPC Operate of response of DeltaV Predict to disturbances and setpoints



## Discussion and Related Issues

In neutralization systems, the piping or dip tube size may have not been reduced to match the small valve capacity. The result is a large process transportation delay that would make the Penalty on Move for the small valve much larger than what is shown in this note. In the extreme, the transportation delay can be so large from an uncoordinated piping or dip tube design that the fine valve is no longer effective. See the book *Advanced pH Measurement and Control* 3<sup>rd</sup> Edition from ISA for details on how to solve this problem by injecting the reagent into a high flow stream. Also, see the article "A Fine Time to Break Away from Old Valve Problems" in the November 2005 issue of Control magazine and the article "What's Your Flow Control Valve Telling You?" in the May 2004 issue of Control Design magazine for a background on control valve problems and how they cause variability in the control loop.

The simultaneous throttling of both valves by Model Predictive Control will reduce the limit cycle from the large valve's dead band and resolution limitations. If the "Maximum MV Rate" parameter shown in Figure 3 is written to zero when a separate filtered value of the "Critical PV" stays within a band around its set point, the limit cycle from the large valve is eliminated. The width of the band can be calculated as the resolution limit or half of the dead band for the large valve, whichever is more significant, multiplied by the process gain in the MPC model for the large valve. Alternately, a DeltaV composite block for backlash and stick-slip compensation can be used to reduce the limit cycle and dead time from the large valve.

In this note, the manipulated variables became valve set points. Signal characterizer blocks could have been added to reduce the effect of nonlinearity from the installed valve characteristic. Flow controllers could have been used to make the effect of an MV move on the Critical PV more linear as well as reduce the effect of valve inlet pressure upsets. However, for neutralization vessels, the inherent valve characteristic is normally chosen to be linear, and the installed characteristic strongly resembles the inherent characteristic and the pressure upsets are minimal because of the generally low reagent flow.

This simple yet effective solution by Model Predictive Control should open up the door to reducing process variability in all types of applications by the addition of precision (fine) control valves.

For those applications where the control valves have an opposite effect on the process such as steam and coolant valves, supply and let down valves, and acid and base valves, a different set up of the model predictive controller is needed to keep both valves from being open at the same time and wasting energy or raw materials.