

**Bridging the Gap between Academia and
Industry:
Rose-Hulman Institute of Technology
Unit Operations Laboratory**

Atanas Serbezov and Ronald Artigue
Department of Chemical Engineering
Rose-Hulman Institute of Technology

Ron Knecht
Cornerstone Controls, Inc

Unit Operations Laboratory Courses at Rose-Hulman Institute of Technology

- The required courses have no laboratory components
- The UO laboratory courses provide hands-on experience
 - Spring JR year – 1 project (1 day/week, 4 hours/day, 10 weeks)
 - Fall SR year – 2 projects (2 days/week, 4 hours/day, 10 weeks)
 - Winter SR year – 2 projects (2 days/week, 4 hours/day, 10 weeks)
- Project selection requirements
 - Fluids
 - Heat Transfer
 - Mass Transfer

Unit Operations Laboratory Facilities at Rose-Hulman Institute of Technology

- 6,500 ft² of laboratory space divided into
 - [High bay area](#)
 - [Low bay area](#)
 - 10 special project labs
- 20+ different laboratory projects
 - Large scale (distillation, absorption and extraction columns)
 - Small scale (heat exchangers, tubular reactor, fermentor)
 - Bench scale (Othmer still, ultrafiltration, emulsions)
 - Instrumentation and Control
 - Prior to 2005 – mostly local gauges, manual operation
 - 2005 to current – DeltaV distributed control system deployment

Role of the Control System in the Unit Operations Laboratory

- Provide safe operation of the UO experiments
 - Maintain the level in the reboiler of the distillation column
- Enable smooth operation by maintaining the specified process conditions
 - Maintain constant pressure drop during filtration
 - Maintain constant mixing ratio and flow rate in the tubular reactor
- Provide reliable process data for further analysis
 - Temperatures, pressures, flow rates
- Record process data for analysis and troubleshooting
 - Perform material and energy balances
 - Determine heat transfer coefficients

DeltaV Process Automation System (PAS) Architecture

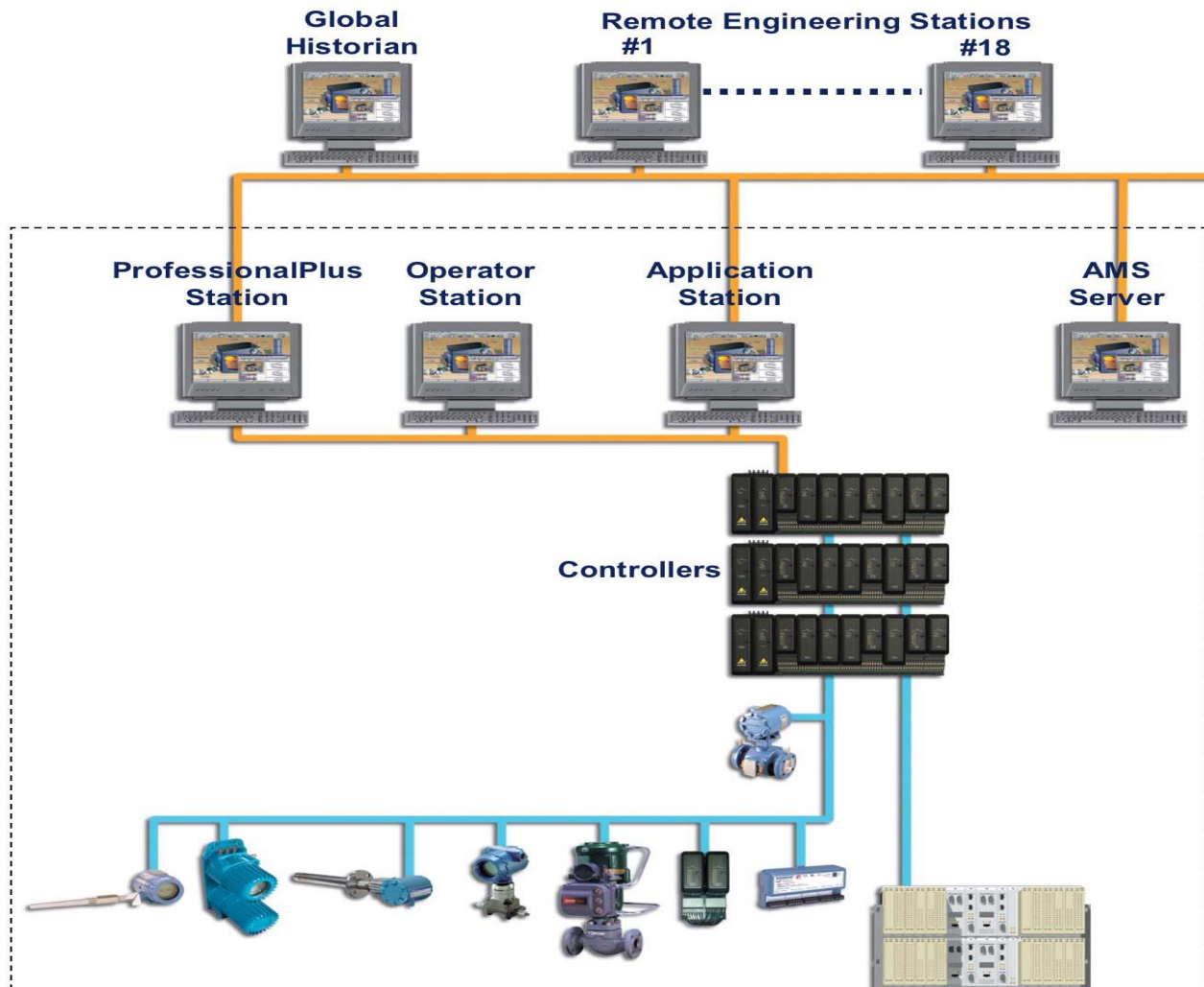

Advantages and Disadvantages of an Industrial Control System in the UO Laboratory

- Advantages
 - Stable and robust control of the experiments
 - Standard control modules
 - Advanced control modules, such as model predictive control
 - Auto tuning capabilities
 - Realistic emulation of actual plant environment
- Disadvantages
 - Cost
 - Complex deployment

Bridging the Gap between Industry and Academia

Additional benefit of the PAS in the UO Laboratory

- Students perform typical Process Engineering duties
 - Process startup sequences
 - Process monitoring
 - Process performance analysis
 - Process troubleshooting
- Enhanced Process Control experience
 - Modern instrumentation and measurements
 - Data storage, retrieval and analysis of historical trends
 - Modern control system architecture and deployment
 - Modern control and tuning algorithms

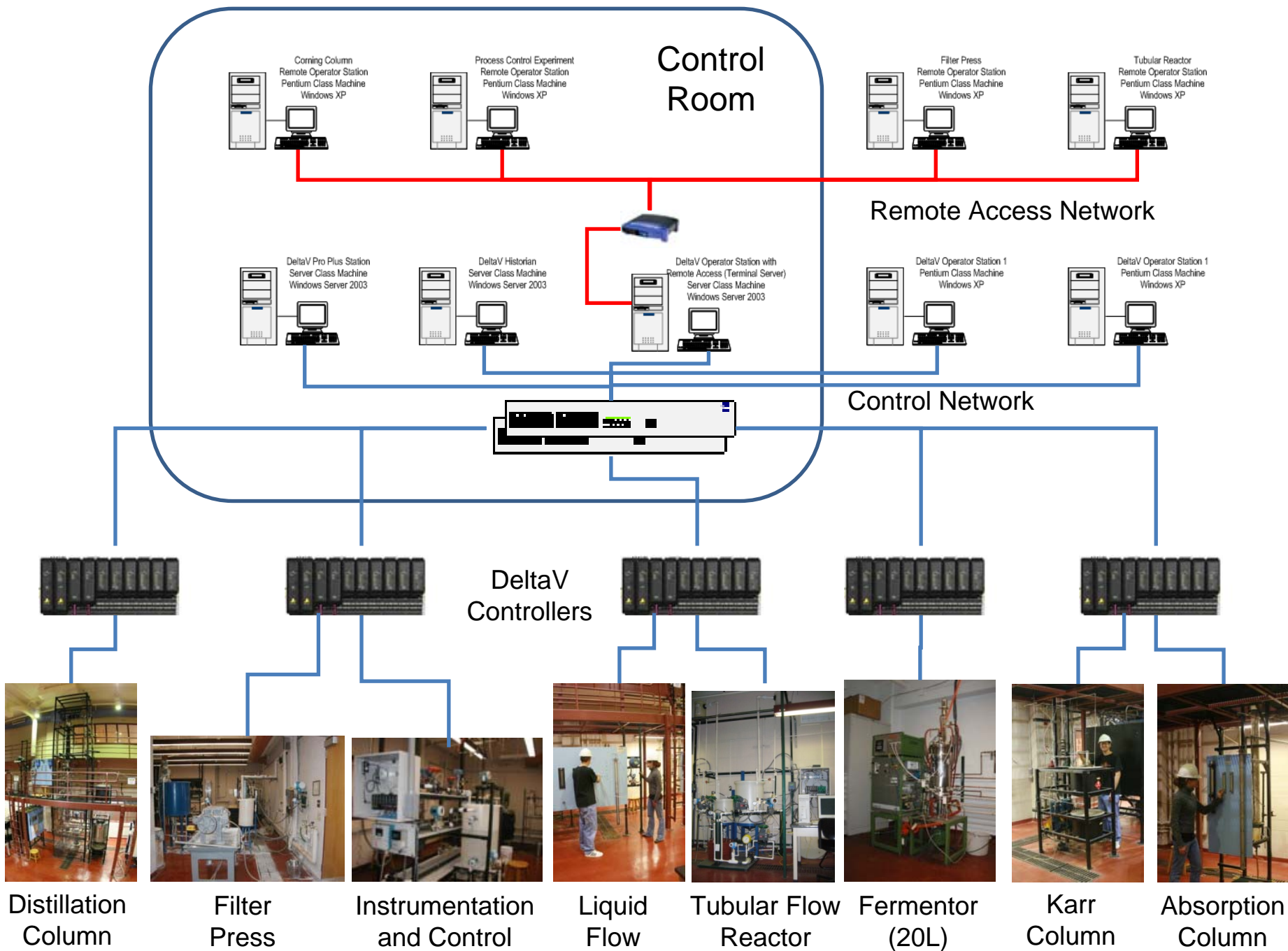

DeltaV Deployment

- **Faculty and staff**
 - Two faculty and one laboratory technician
- **Industrial support**
 - Technical advice from the corporate control department at Eli Lilly and Company
 - Technical support from the equipment manufacturers
- **Special UO laboratory projects**
 - Revamping of existing experiments
- **Project based course**
 - Advanced Process Control
- **Directed research**
 - Undergraduate and graduate students

Industrial Collaboration

- **Donation of equipment**
- **Donation of cash**
- **Sabbatical leaves for the involved faculty**
- **Technical advice**
- **On-site service visits**
- **Training courses at reduced fees**
- **Equipment purchase at cost**

Challenges

- **Cost of equipment**
 - Solution: Collaborate with industry
- **Steep learning curve for deployment**
 - Solution: industrial support for sabbatical projects
- **Significant time requirements**
 - Solution: Involve students in project-based special courses
- **Significant IT requirements**
 - Solution: Possible involvement of the Electrical and Computer Engineering departments

Conclusions

- **The PAS creates a stable environment conducive for the engineering analysis of the laboratory experiments**
- **The PAS bridges the gap between industry and academia**
- **Students are both users and developers**
- **Industry involvement is crucial**
- **Students like the new developments**